

# AMPFIBIAN X1 HEAVY-DUTY WEATHERPROOF CONNECTOR PROTECTOR

Mfgr.# 92837

## INSTRUCTIONS

1. Unclip both HOUSING CLIPS (3) to open unit.
2. Rotate both LEVER CLAMPS (5) until they *click* into place.
3. Insert plug & socket in centre of LOWER HOUSING (2).
4. Clamps (5,6) *release automatically* when LID (1) is closed.
5. Ensure both HOUSING CLIPS (3) are fully latched.
6. Optional: use FLIP-OUT HANGER (7) to hang up.
7. Optional: place padlock through SECURING LOOP (8).

- |                       |                   |
|-----------------------|-------------------|
| 1 UPPER HOUSING (LID) | 5 LEVER CLAMP     |
| 2 LOWER HOUSING       | 6 CLAMP           |
| 3 HOUSING CLIPS       | 7 FLIP-OUT HANGER |
| 4 CORD SEALS          | 8 SECURING LOOP   |

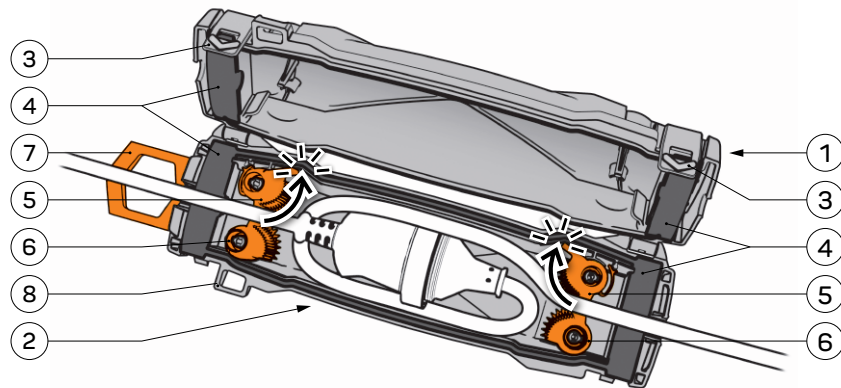

## WARNINGS

- Do not operate frozen seals: allow to thaw before opening/closing!
- Do not expose to petrol, oil, solvents, harsh chemicals, etc.!
- Do not use in hazardous areas and/or in the presence of corrosive, oxidising and/or explosive materials, gases, vapours, etc.!
- Do not use if seals missing or damaged!
- Do not immerse!
- Do not disassemble!
- Temporary use only, not for permanent installation!
- Only insert cords if dry and if unit is dry inside!
- Do not bury!
- Do not use if housing is damaged!
- Disconnect power supply before handling connections!



## SPECIFICATIONS

- Suitable for ordinary and heavy duty cords from Ø8mm to Ø12mm diameter. Cleats successfully tested to 100kg.
- Impact rated to IK09.
- Ingress protected to IP55.



## INSTRUCTIONS

- Use clean and undamaged electrical cords.
- Check all seals are in place, undamaged and clean.
- Ensure clamps rotate freely before use.
- Confirm housing clips are fully latched when closed.
- Store open (un-latched) in a dry place out of direct sunlight.
- Remove condensation/moisture with a clean dry cloth.



## LIMITED WARRANTY

Every Ampfibian product is thoroughly inspected and tested before leaving our factory. Ampfibian Pty. Ltd. limits this warranty against defective workmanship and faulty materials for twelve (12) months from date of purchase (proof of date of purchase must be provided) and undertakes at its option to repair or replace each product or part thereof on condition that: (a) the product has not been subject to misuse, neglect, accidents or alterations; (b) the unit has been used and maintained as per the instructions. Ampfibian Pty. Ltd. is not liable for any consequential damage to either people, work or facilities from using the product. Buyers sole remedy against manufacturer shall be the replacement of the defective product. Because applications vary, no use or suitability warranty is implied or intended. It is the buyers responsibility to determine if the product will adequately protect the user. Careful analysis should be made before selecting equipment for a particular work environment. Please see the "Return & Refund Policy" page on our website or contact us for details. All shipping costs are the responsibility of the customer. Please include your purchase receipt (or a copy) as proof-of-purchase in the event of a warranty claim.

LOOP THINNER LEAD IF POSSIBLE!



## NOTES

- The housing seals to IP55 with cords up to Ø12mm (almost Ø½") when closed, and maintains IP55 without cords inserted.
- The clamps help to retain cords from Ø8mm to Ø12mm. Smaller diameter cords are sealed, but not retained.
- Clamps provide protection from accidental disconnection, but cords must not be under permanent tension while in use.
- Differences between temperature, pressure and humidity inside and outside the unit will lead to condensation inside.
- Electricity is dangerous, use caution!

## LEGAL

- In case of warranty claims please contact your place of purchase. Please keep purchase receipt and instructions with the product.
- The function and appearance of this product are protected.



PET  
Packaging



PC/POM  
Clear/Orange



Paper



IP55 to AS-60529:2004 IK09 to IEC-62262:2002

TÜVRheinland®



Ampfibian Pty Ltd  
3/33 Southern Cross Drive  
Ballina NSW 2478 Australia  
sales@ampfibian.com.au  
Freecall 1800 342-426  
[ampfibian.com.au](http://ampfibian.com.au)



1781-VAC-INSTRUCT-A

Register your warranty online at [ampfibian.com.au](http://ampfibian.com.au)